

# Makita Service Information / Model: HR4500C

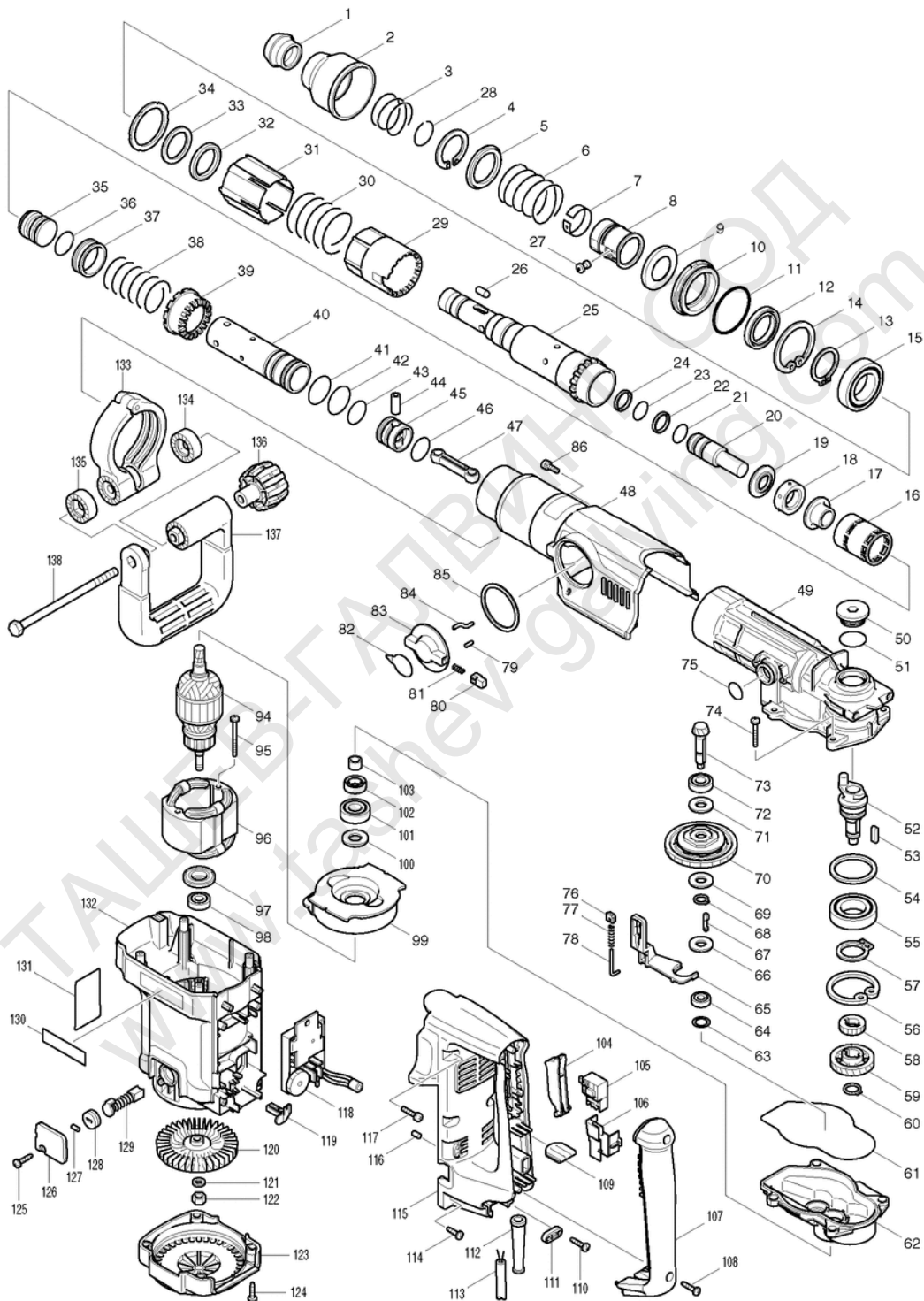

POS	Bestell-Nr.	Artikelbeschreibung	Stk.
1	286259-5	WERKZEUGHALTER-KAPPE HR4500C	1
2	417459-8	BOHRFUTTERDECKEL HR4500C	1
3	233178-6	DRUCKFEDER 46 HR4000C/HR4500C	1
4	961186-4	SEEGERING WR-40 HR4500C	1
5	344489-5	SCHEIBE 40 HR4000C/HR4500C	1
6	233179-4	DRUCKFEDER 50 HR4000C/HR4500C	1
7	232171-7	BLATTFEDER 37 HR4000C/HR4500C	1
8	322948-9	BOHRFUTTERRING HR4000C/4500C	1
9	344488-7	ABDECKKAPPE 32 HR4000C/4500C	1
10	417435-2	DICHTUNGSGEHÄUSE HR4500C	1
11	213669-3	O-RING 56 HR4500C/AN923/943	1
12	213480-3	SIMMERRING 35 HR4000C/4500C	1
13	961153-9	SEEGERING S-35 961153-9	1
14	962301-3	SEEGERING R-62	1
15	211471-8	KUGELLAGER 6007LLU HR4500C	1
16	417434-4	GLEITHÜLSE HR4500C	1
17	331589-0	HÜLSE 19 HR4500C	1
18	421767-1	GUMMIRING 22 HR4500C	1
19	331597-1	SCHEIBE 19 HR4500C	1
20	324088-9	SCHLAGBOLZEN HR4500C	1
21	213317-4	O-RING 20 HR4000/4500/4011C/	1
22	213392-0	FLUORIDRING 25 HR4000/4500/4	1
23	213317-4	O-RING 20 HR4000/4500/4011C/	1
24	213392-0	FLUORIDRING 25 HR4000/4500/4	1
25	324064-3	WERKZEUGHALTER HR4500C	1
26	322908-1	ROLLE 8 322908-1	2
27	310052-6	ANSATZSTIFT 8 HR4000C/4500C	1
28	231984-3	RINGFEDER 25 HR3541FC	1
29	417437-8	FIXIERRING A HR4500C	1
30	233300-5	DRUCKFEDER 55 HR4500C	1
31	417436-0	FIXIERRING B HR4500C	1
32	262093-7	RING 35 HR4500C	1
33	267221-9	SCHEIBE 35 HR4500C	1
34	267222-7	SCHEIBE 49 HR4500C	1
35	324089-7	SCHLÄGER HR4500C	1
36	213440-5	O-RING 27 HR4500C	1
37	331599-7	RING 38 HR4500C	1
38	233299-4	DRUCKFEDER 39 HR4500C	1
39	227401-9	TELLERRAD 36 HR4500C	1
40	331592-1	ZYLINDER 34 HR4500C	1

POS	Bestell-Nr.	Artikelbeschreibung	Stk.
41	213486-1	O-RING 35 HR4500C/6827	1
42	213486-1	O-RING 35 HR4500C/6827	1
43	213440-5	O-RING 27 HR4500C	1
44	331598-9	ROHR 10 HR4500C	1
45	417433-6	KOLBEN HR4500C	1
46	213440-5	O-RING 27 HR4500C	1
47	417432-8	PLEUEL HR4500C	1
48	152766-9	GETRIEBEGEHÄUSEDECKEL HR4500C	1
49	152764-3	GETRIEBEGEHÄUSE HR4500C	1
50	416124-6	GETR.GEH.DECKEL (RUND)	1
50.2	416124-6	<a href="#">GETR.GEH.DECKEL (RUND)</a>	1
51	213406-5	O-RING 30	1
52	324065-1	KURBELWELLE HR4500C	1
53	254218-7	KEIL 5 HR4500C	2
54	267219-6	SCHEIBE 45 HR4500C	1
55	211418-2	KUGELLAGER 6006LLU HR4500C	1
56	962252-0	SEEGERING R-55 HR4500C	1
57	961110-7	SEEGERING S-30 961110-7	1
58	227017-0	ZAHNRAD 22 HR4500C	1
59	226533-9	ZAHNRAD 37 HR4500C	1
60	961056-7	SEEGERING S-16 961056-7	1
61	421768-9	DICHTUNGSRING HR4500C	1
62	152765-1	GETRIEBEGEHÄUSE HR4500C	1
63	253314-8	SCHEIBE 15 253314-8	1
64	210024-0	KUGELLAGER 608 2RS	1
65	417438-6	UMSCHALTGELENK HR4500C	1
66	253810-6	SCHEIBE 12 253810-6	1
67	322951-0	UMSCHALTKEIL 322951-0	2
68	961052-5	SEEGERING S-12	1
69	267113-2	SCHEIBE 12	1
70	152763-5	RUTSCHKUPPLUNG HR4500C	1
70.2	152954-8	<a href="#">RUTSCHKUPPLUNG HR4500C neu</a>	1
71	267113-2	SCHEIBE 12	1
72	211138-8	KUGELLAGER 6001LLU 211138-8	1
73	227405-1	ZAHNRAD 10 HR4500C	1
74	266012-5	SELBSTSCHNEID.SCHRAUBE 5x35	4
75	213304-3	O-RING 20 213304-3	1
76	416289-4	GLEITPLATTE 416289-4	1
77	233180-9	DRUCKFEDER 3 233180-9	1
78	322963-3	FÜHRUNGSSTIFT 2 322963-3	1

POS	Bestell-Nr.	Artikelbeschreibung	Stk.
79	256122-6	STIFT 4 256122-6	1
80	417340-3	SPERRKNOPF 417340-3	1
81	233188-3	DRUCKFEDER 2.4 BST110	1
82	816329-2	ETIKETTE 816329-2	1
83	416287-8	UMSCHALTER 416287-8	1
84	322962-5	GETRIEBESTIFT 4 HR4000C/4500C	1
85	421698-4	STAUBSCHUTZSCHEIBE 55 neu	1
86	911128-8	SCHRAUBE M4x16 HM3541FC	1
94	516843-5	ANKER HR4500C	1
94		*** INC. 97,98	
94.2	516843-5	<a href="#">ANKER HR4500C</a>	1
94.2		*** INC. 97,98,103	
95	266046-8	SELBSTSCHNEID. SCHRAUBE 5x50	2
96	526113-4	FELD HR4500C	1
97	681642-5	ISOLIERSCHEIBE HM1213C	1
98	211088-7	KUGELLAGER 6000DDW	1
99	417439-4	LUFTABLEITPLATTE HR4500C	1
100	267025-9	DISTANZSCHEIBE 15 267025-9	1
101	211238-4	KUGELLAGER 6202LLU 211238-4	1
102	213231-4	SIMMERRING 15 HR4500/HM0860/HR	1
103	331596-3	HÜLSE 12 HR4500/4011C/HM0860	1
104	416284-4	SCHALTERHEBEL 416284-4	1
105	651922-3	SCHALTER TG71B	1
106	416126-2	UMMANTELUNG FÜR SCHALTER	1
107	417443-3	GRIFFSCHALE HR4500C	1
108	265995-6	SELBSTSCHN.SCHRA 4x18 BO5030	2
109	421583-1	SCHAUMGUMMI 421583-1	1
110	265995-6	SELBSTSCHN.SCHRA 4x18 BO5030	2
111	687053-2	KABELKLEMMPLATTE neu	1
112	682560-0	KABELSCHUTZ 10 HM3541FC	1
113	695123-3	KABEL 1.5-2-4.0 KP312S	1
114	266021-4	SELBSTSCHNEID. SCHRAUBE 5x20	4
115	417444-1	HANDGRIFF HR4500C	1
116	416285-2	STIFT 5 416285-2	2
117	911233-1	SCHRAUBE M5x20 HR3541FC	2
118	631433-4	REGELELEKTRONIK HR4500C	1
119	417431-0	FIXIERSTAB HR4500C	1
120	240016-5	LÜFTERRAD 90 HR5001C/HR4500C	1
121	253165-9	U-SCHEIBE 8	1
122	931403-6	MUTTER M8	1

POS	Bestell-Nr.	Artikelbeschreibung	Stk.
123	417441-7	MOTORGEHÄUSEDECKEL HR4500C	1
124	266021-4	SELBSTSCHNEID. SCHRAUBE 5x20	4
125	265995-6	SELBSTSCHN.SCHRA 4x18 BO5030	2
126	416292-5	KOHLHALTERDECKEL 416292-5	2
127	263002-9	GUMMISTIFT 4 FS2300-6300	2
128	643650-4	KOHLKAPPE 6.5x18 (CB153)	2
129	181048-2	KOHLN CB-155 SELBSTABSCHALT	1
130	819064-1	ETIKETTE " M A K I T A "	2
131	852945-6	TYPENSCHILD HR4500C	1
132	183332-1	MOTORGEHÄUSE HR4500C	1
132		*** INC. 130	
133	152768-5	SEITENGRIFFHALTEPLATTE HR4500C	1
134	417002-3	Halterung f. SCHELLE. HM1213	1
135	417002-3	Halterung f. SCHELLE. HM1213	1
136	252640-2	FLÜGELMUTTER M8 HM1213C	1
137	417003-1	SEITLICHER GRIFF HM1213C	1
138	265439-6	6-KANTSCHRAUBE M8x15 HM1213C	1
1001	181573-3	Fett f.Bohrer&Meißelsch HR3541	1
1001.2	181573-3	<a href="#">Fett f.Bohrer&amp;Meißelsch HR3541</a>	1
1001.3	194683-7	<a href="#">Fett f. Bohrer &amp; Meißelschaft</a>	1
1002	824607-6	TRANSPORTKOFFER HR4500C	1
1003	321248-4	TIEFENANSCHLAG 370MM HR3541FC	1
1004	152554-4	GRIFF 36 152554-4	1
1005	265701-9	SCHRAUBE M6x14 HR3541FC	1
1006	266163-4	SCHRAUBE M8x80 HR3541FC	1
1007	344492-6	PLATTE HR3541FC	1
1008	344949-7	GRIFF-FEDER 75 HR4500C	1
1009	417442-5	SEITENGRIFFHALTEPLATTE 75	1
1010	931302-2	MUTTER M6 HR3541FC	1
2001	134915-0	Seitlicher Griff kpl (D-Griff)	1
2001		*** INC. 133-138	
2002	134916-8	GRIFF 36 kpl. HR4500C	1
2002		*** INC. A03-A10	